

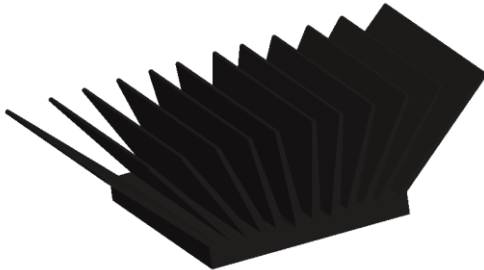

LED 300 Series Heat Sinks

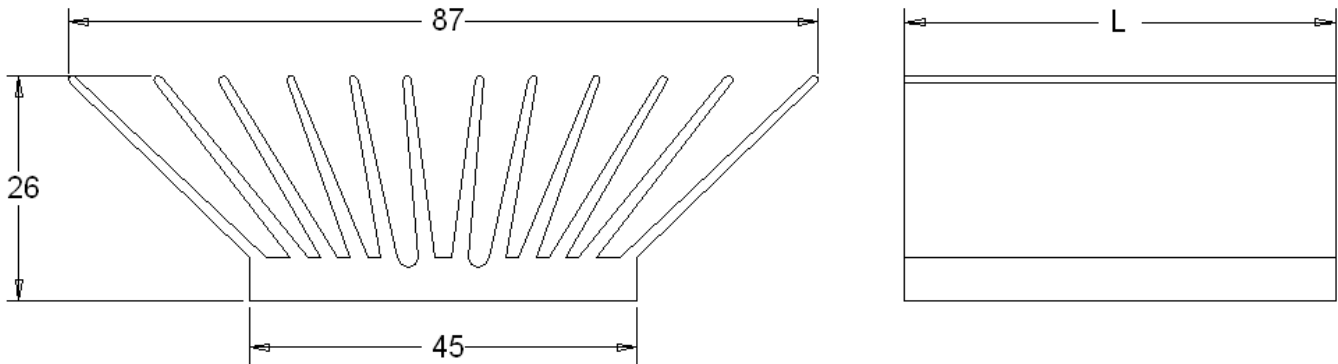

Smart Heatsinks, Inc. offers the standard, LED 300 series, low cost and easy assembly linear heat sinks for LEDs by reducing LED temperature by more than 50%. This simple heat sink can be used for LED lighting products. The heat sink has two types of surface finishes. and can be used in either natural (free) or forced convection cooling applications.



MECHANICAL OUTLINE (UNIT: MM)

SPECIFICATOINS

Heat Sink: Aluminum Alloy 6063-T5 or Equivalent with either degreased or black anodized finish.

Compliance: Either degreased or black anodized finished parts are compliant with RoSH.

Standard Part Number	Length "L" (in / mm)	Surface Area (in ² / mm ²)	Weight (lb / kg)
SHS-LED-305-D	11.9 / 305	327 / 210,767	11.0/5.0
SHS-LED-305-B			
SHS-LED-330-D	13.0 / 330	356 / 229,548	12.1/5.5
SHS-LED-330-B			

THERMAL PERFORMANCE

"L" =	305 mm	330 mm
Velocity (Ft/Min)	Thermal Resistance (°c/w)	
200	1.3	1.2
300	0.8	0.7
400	0.6	0.6
500	0.5	0.5
600	0.4	0.4
700	0.4	0.4
800	0.3	0.4

ORDERING INFORMATION

Standard P/N	Descriptions	Packaging
SHS-LED-305-D	Degreased, 305mm LG	Bulk
SHS-LED-305-B	Black Anodized, 305mm LG	Bulk
SHS-LED-330-D	Degreased, 330mm LG	Bulk
SHS-LED-330-B	Black Anodized, 330mm LG	Bulk